

# Model: 1600

## Cast Iron CHEXTER™ Check Valves Sizes: 2" - 36" (50 - 900mm)

Pressure/Temperature - Non-Shock		
Size	Material	Rating
1600-D 2-12"	Cast Iron	190psi @ 150°F
		13.10 bar @ 65.56°C
		125psi @ 450°F
14-24"	Cast Iron	8.62 bar @ 232.22°C
		150psi @ 150°F
		10.34 bar @ 65.56°C
30" and up	Cast Iron	100psi @ 353°F
		6.89 bar @ 178.33°C
		150psi @ 100°F
		10.34 bar @ 37.78°C
		50psi @ 300°F
		3.45 bar @ 148.89°C

### Typical Services

Can be used in a variety of applications. Included are:

- Chilled and hot water systems
- Refrigeration, plumbing, air conditioning
- Gas and liquid applications
- Water filtration, oxygen systems, boiler feed lines
- Centrifugal pump and compressor systems

### Features

- Compact design with short face-to-face dimensions for minimum space requirements.
- Single moving part insures long, trouble-free service life.
- Seal-ring is one piece, easily replaceable in the field.
- Interchangeable parts for ease of maintenance.
- Operates fully at low pressure differential.
- Spring returns disc to fully closed position prior to reverse flow, minimizing water hammer.
- Disc is counter-weighted, utilizing gravity to additionally insure closure.
- Soft seal is located out of the flow path to reduce erosion effects.
- High C<sub>v</sub> values due to aerodynamic disc shape and near full port opening.
  - Superior to other check valve designs, similar to Butterfly Valves

### Construction

- Robust cast body is wafer style, featuring compact face-to-face dimensions to fit in small spaces.
- Designed to fit within ANSI bolt circles.
- Variety of trim and seat materials are available.
  - Parts are interchangeable
- Disc rotates on the hinge pin, creating very low pivot friction, so little wear in operation.

### Installation

- Can be installed horizontally or vertically.
  - Consult factory for downward vertical flow applications.
  - In horizontal applications, valve should be installed top up, with shaft aligned horizontally with the top up (hinge pin plugs are above the pipe centerline)
- Good piping practice recommends installing a distance of 5 to 10 pipe diameters from elbows, pumps, or others turbulence-creating devices.
- Mueller Steam Specialty strongly recommends the installation of a strainer ahead of the pump to ensure protection of both the pump and the valve from foreign particles.

### Materials

- See Introduction page of the CHEXTER™ Check Valve section of the Mueller Steam Specialty Engineering binder for standard materials and How To Order instructions.

1600

Class 125



Model 1600  
Front



Open

Job Name \_\_\_\_\_

Contractor \_\_\_\_\_

Job Location \_\_\_\_\_

Approval \_\_\_\_\_

Engineer \_\_\_\_\_

Contractor's P.O. No. \_\_\_\_\_

Approval \_\_\_\_\_

Representative \_\_\_\_\_

# Dimensions

## Raised Face And Flat Face Valves

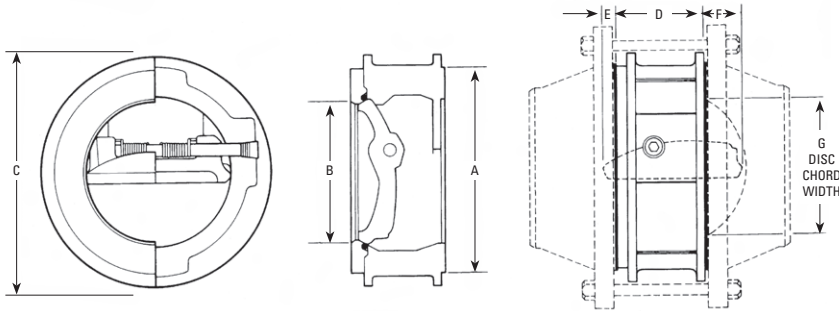

2" – 14" (50 – 350)

LINE SIZE		DIMENSIONS												
		A		B	C		D		E		F		G	
in.	mm	in.	mm	SAME VALVE FITS SCHEDULE 40 AND 80 LINE SIZES	125 CLASS		in.	mm	in.	mm	in.	mm	in.	mm
2	50	3 <sup>5</sup> / <sub>8</sub>	92.1		4 <sup>1</sup> / <sub>8</sub>	104.8	1 <sup>1</sup> / <sub>2</sub>	38.1	0	0	1/2	12.7	1 <sup>15</sup> / <sub>16</sub>	33.3
2 <sup>1</sup> / <sub>2</sub>	65	4 <sup>1</sup> / <sub>8</sub>	104.8		4 <sup>7</sup> / <sub>8</sub>	123.8	1 <sup>15</sup> / <sub>16</sub>	49.2	1/16	1.6	9/16	14.3	2 <sup>7</sup> / <sub>8</sub>	60.3
3	80	5	127.0		5 <sup>3</sup> / <sub>8</sub>	136.5	2 <sup>1</sup> / <sub>8</sub>	54.0	1/8	3.2	3/4	19.1	2 <sup>7</sup> / <sub>8</sub>	73.0
4	100	6 <sup>3</sup> / <sub>16</sub>	157.2		6 <sup>7</sup> / <sub>8</sub>	174.6	2 <sup>3</sup> / <sub>4</sub>	69.9	1/8	3.2	1 <sup>1</sup> / <sub>8</sub>	28.6	3 <sup>3</sup> / <sub>8</sub>	98.4
5	125	7 <sup>5</sup> / <sub>16</sub>	185.7		7 <sup>3</sup> / <sub>4</sub>	196.9	3 <sup>1</sup> / <sub>2</sub>	88.9	7/16	11.1	1 <sup>3</sup> / <sub>8</sub>	34.9	4 <sup>1</sup> / <sub>16</sub>	103.2
6	150	8 <sup>1</sup> / <sub>2</sub>	215.9		8 <sup>3</sup> / <sub>4</sub>	222.3	4 <sup>1</sup> / <sub>8</sub>	104.8	5/8	15.9	1 <sup>1</sup> / <sub>4</sub>	31.8	4 <sup>15</sup> / <sub>16</sub>	125.4
8	200	10 <sup>5</sup> / <sub>8</sub>	269.9		11	279.4	5 <sup>3</sup> / <sub>8</sub>	136.5	1	25.4	1 <sup>15</sup> / <sub>16</sub>	49.2	6 <sup>7</sup> / <sub>8</sub>	174.6
10	250	12 <sup>3</sup> / <sub>4</sub>	323.9		13 <sup>3</sup> / <sub>8</sub>	339.7	6 <sup>1</sup> / <sub>16</sub>	169.9	1 <sup>1</sup> / <sub>2</sub>	38.1	2 <sup>3</sup> / <sub>8</sub>	60.3	8 <sup>3</sup> / <sub>8</sub>	212.7
12	300	15	381.0		16 <sup>1</sup> / <sub>8</sub>	409.6	8	203.2	2 <sup>1</sup> / <sub>16</sub>	52.4	2 <sup>7</sup> / <sub>16</sub>	61.9	9 <sup>3</sup> / <sub>8</sub>	238.1
14	350	16 <sup>1</sup> / <sub>4</sub>	412.8	17 <sup>3</sup> / <sub>4</sub>	450.9	8 <sup>3</sup> / <sub>4</sub>	222.3	1 <sup>1</sup> / <sub>2</sub>	38.1	2 <sup>1</sup> / <sub>4</sub>	57.2	9 <sup>3</sup> / <sub>4</sub>	235.0	

\*"D" dimensions (overall face-to-face) are for 125-600 Class.

\*"D" dimensions for 900 Class same as RTJ "D" dimensions on page 10.

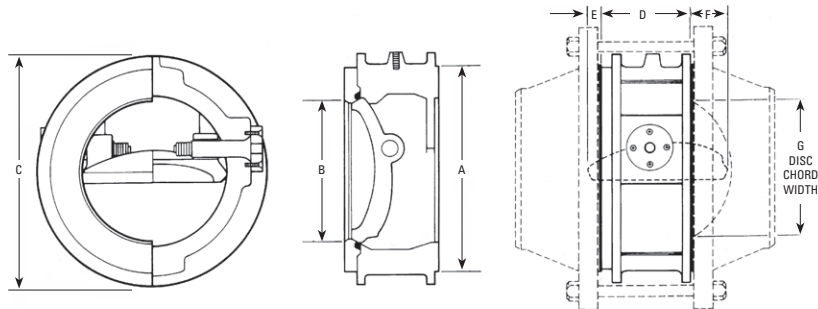

16" – 36" (400 – 900)

LINE SIZE		DIMENSIONS												
		A		B	C		D*		E		F		G	
in.	mm	in.	mm	SAME VALVE FITS SCHEDULE 40 AND 80 LINE SIZES	125 CLASS		in.	mm	in.	mm	in.	mm	in.	mm
16	400	18 <sup>1</sup> / <sub>2</sub>	469.9		20	508.0	9 <sup>1</sup> / <sub>4</sub>	235.0	1 <sup>11</sup> / <sub>16</sub>	42.9	4 <sup>5</sup> / <sub>8</sub>	117.5	13 <sup>3</sup> / <sub>4</sub>	349.3
18	450	21	533.4		21 <sup>1</sup> / <sub>4</sub>	539.8	10 <sup>3</sup> / <sub>8</sub>	263.5	1 <sup>1</sup> / <sub>2</sub>	38.1	5"	127.0	15 <sup>1</sup> / <sub>2</sub>	393.7
20	500	23	584.2		23 <sup>1</sup> / <sub>2</sub>	596.9	11 <sup>1</sup> / <sub>4</sub>	285.8	2 <sup>1</sup> / <sub>2</sub>	63.5	6 <sup>1</sup> / <sub>8</sub>	155.6	17 <sup>3</sup> / <sub>8</sub>	447.7
24	600	27 <sup>1</sup> / <sub>4</sub>	692.2		27 <sup>7</sup> / <sub>8</sub>	708.0	12 <sup>1</sup> / <sub>2</sub>	317.5	3 <sup>1</sup> / <sub>4</sub>	82.6	6 <sup>3</sup> / <sub>4</sub>	171.5	20 <sup>3</sup> / <sub>4</sub>	527.1
30	760	33 <sup>3</sup> / <sub>4</sub>	857.3		34 <sup>3</sup> / <sub>8</sub>	873.1	15 <sup>1</sup> / <sub>2</sub>	393.7	5 <sup>5</sup> / <sub>8</sub>	142.9	8 <sup>3</sup> / <sub>16</sub>	208.0	26 <sup>1</sup> / <sub>2</sub>	673.1
36	900	40 <sup>1</sup> / <sub>4</sub>	1022.4		40 <sup>7</sup> / <sub>8</sub>	1038.2	18"	457.2	5 <sup>5</sup> / <sub>16</sub>	134.9	12"	304.8	33 <sup>3</sup> / <sub>4</sub>	844.6

Mueller Steam Specialty product specifications in U.S. customary units and metric are approximate and are provided for reference only. For precise measurements, please contact Mueller Steam Specialty Technical Service. Mueller Steam Specialty reserves the right to change or modify product design, construction, specifications, or materials without prior notice and without incurring any obligation to make such changes and modifications on Mueller Steam Specialty products previously or subsequently sold.

